

FRENCH DOOR REFRIGERATOR

EW28BS87SS

Featuring Wave-Touch® Electronic Controls



PRODUCT DIMENSIONS

Height	69-7/8"
Width	36"
Depth	33-3/8"

MORE EASY-TO-USE FEATURES

WAVE-TOUCH® CONTROLS OFFER UNDERSTATED ELEGANCE IN THE KITCHEN

Sleek and subtle – the elegant design of the Wave-Touch® Control Panel only activates upon your touch and fades away to display just the program selected.

PLATINUM STAR® LIMITED WARRANTY

Our exclusive limited warranty that includes three years coverage on parts and one year on labour.¹

LUXURY-DESIGN® GLASS SHELVES

Fit even large entertaining platters with sleek, spacious glass shelves.

LUXURY-DESIGN® LIGHTING

Our designer LED lighting ramps up and is as beautiful as it is functional.

LUXURY-GLIDE® FREEZER DRAWERS FOR EFFORTLESS ACCESS TO ITEMS

Access it all — our Luxury-Glide® Freezer drawers glide out smoothly and fully extend, letting you see every last item inside.

PUREADVANTAGE® FILTRATION SYSTEMS

Our filtration system keeps clean, filtered air circulated throughout and our 3M® water filter keeps fresh, clean water and ice at your fingertips.

STAY INFORMED WITH THE REFRIGERATION ALARM SYSTEM

Rest assured with our Refrigeration Alarm System, which alerts you to important changes, including power failures, an open door and elevated freezer temperatures.

FULL-EXTENSION FREEZER BASKETS

Baskets give you additional functional space to organize and store more.

Available in:



Stainless
(S)

¹Eligibility based on product registration with Electrolux North America within 60 days of purchase. Products must have been purchased on or after July 1, 2013. Coverage includes material parts for 3 years and labour for 1 year.

SIGNATURE FEATURES



PERFECT TEMP® DRAWER KEEPS FAVOURITES AT THEIR IDEAL TEMPERATURE

Delight your guests by serving everything at its ideal temperature — the Perfect Temp® Drawer offers a customizable range of 28-38 degrees and preset options for favourites, such as wine and cheese.



CRISPER DRAWERS KEEP FRUITS AND VEGGIES AT THEIR MOST DELICIOUS

Veggies and fruits retain their just-picked taste with our Adjustable Humidity-Controlled Crisper Drawers that lock in freshness longer.



STANDARD-DEPTH DESIGN

Provides all the space you need to keep all your fresh ingredients on hand.



SELF-CLOSING DOORS GIVE YOU PEACE OF MIND

Maintain your desired temperature in the refrigerator while never worrying about accidentally leaving the door open.

FRENCH DOOR REFRIGERATOR

EW28BS87SS



27 CU.FT. STANDARD-DEPTH FRENCH DOOR REFRIGERATOR

CAPACITIES

Total Capacity	26.7 Cu. Ft.
Fresh Food Volume	17.98 Cu. Ft.
Freezer Volume	8.73 Cu. Ft.
Total Shelf Area	31.8 Sq. Ft.
Fresh Food Shelf Area	24.28 Sq. Ft.
Freezer Shelf Area	7.52 Sq. Ft.

EXTERIOR

Signature Soft-Arc Door and Handle Design	Yes
Electronic Controls	Wave-Touch®
Hidden Hinge Door Design	Yes
Ice/Water Dispenser	Yes
Perfect Set® Temperature Control System and Display	Yes
Crushed Ice / Cube Ice / Water	Yes / Yes / Yes
Air and Water Filter Indicator / Reset	Yes
Ice Maker On / Off	Yes
Fast Freeze™	
Lock / Dispenser Light Control	Yes / Yes

FRESH FOOD CONVENIENCES

PureAdvantage® Water & Ice	Yes
PureAdvantage® Air Filtration / Water Filter Location	Yes / Top Right
Temp Alarm System / Door Ajar Alarm	Yes / Yes
Power Failure Alarm	Yes
Luxury-Design® Glass Shelves	Flat, Lift-Off
Humidity-Controlled Left Crisper	Luxury-Glide®
Humidity-Controlled Right Crisper	Luxury-Glide®
Perfect Temp® Drawer	Luxury-Close™
Cool Zone™ Drawer	
Wine and Beverage Rack	Yes
Dispenser Bin	Yes
Clear Gallon Door Bins (Adjustable)	2
Clear 2-Litre Door Bins (Removable)	1
Clear Condiment Bin	1
Clear Tilt-Out Can Racks	2
Luxury-Design® LED Ramp-Up Multilevel Lighting	Yes
Automatic Ice Maker	Yes

FREEZER CONVENIENCES

Automatic Ice Maker (Second Ice Maker)	Optional
Luxury-Glide® Self-Closing Drawer	Yes
Sliding Freezer Baskets	Yes
Soft Freeze™ Bin / Wire Pizza Slot	No / Yes
Plastic Basket Tray	Yes
Luxury-Design® LED Ramp-Up Multilevel Lighting	

ADDITIONAL FEATURES

ENERGY STAR®	
Sabbath Mode (Star-K® Certified)	Yes

SPECIFICATIONS

Colour –	
Stainless Steel	S
Power Supply Connection Location	Right Bottom Rear
Water Inlet Location	Left Bottom Rear
Voltage Rating	120V / 60 Hz
Connected Load (kW Rating) @ 120 Volts†	1.02
Minimum Circuit Required (Amps)	15
Shipping Weight (Approx.)	365 Lbs.

† An electrical supply with grounded three-prong receptacle is required. The power supply circuit must be installed in accordance with national and local codes & ordinances.

NOTE: Always consult local and national electric and plumbing codes. Refer to Product Installation Guide for detailed installation instructions on the web at electroluxappliances.ca.

Specifications subject to change.

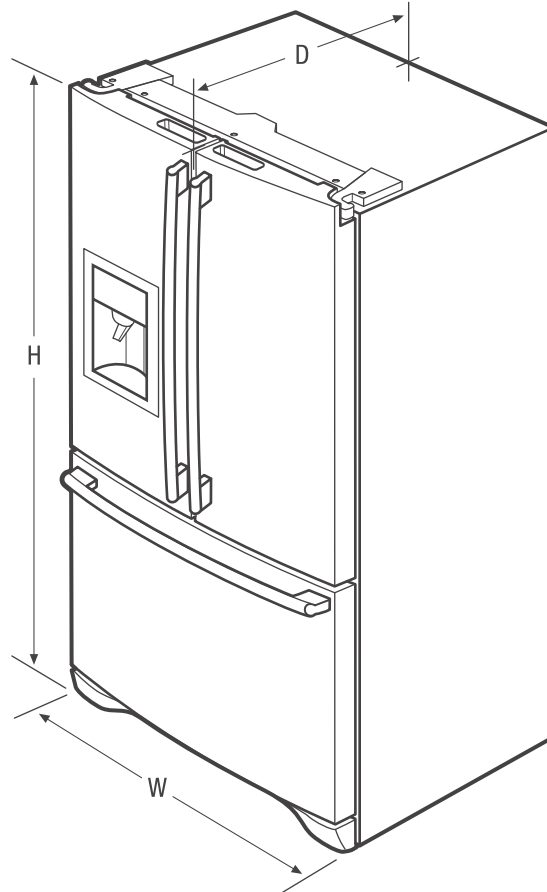

PRODUCT DIMENSIONS

Height (Including Door)	70-1/8"
Width	36"
Depth (Including Door)	33-3/8"
(with Door 90° Open)	47-3/8"
(with Drawer Fully Extended)	55-1/2"

Electrolux Major Appliances, N.A.

CANADA • 5855 Terry Fox Way • Mississauga, ON L5V 3E4 • 1-800-265-8352 • electroluxappliances.ca

EW28BS87S 10/16

© 2016 Electrolux Major Appliances, N.A.



High standards of quality at Electrolux Home Products, Inc. mean we are constantly working to improve our products. We reserve the right to change specifications or discontinue models without notice.

Printed in Canada