BERTAZZONI PROFESSIONAL SERIES

36" SEGMENTED COOKTOP

PM36 3 0G X

HIGHLIGHTS

- Bertazzoni's exclusive dual zone power burner in cast brass delivers high-efficiency performance from a delicate low simmer to full power (750-18,000 BTUs) with best-in-class heat-up time.
- Sear or cook food directly on the electric stainless steel griddle. The two zone temperature controls allow for griddle cooking at up to 450°F.
- The one-touch, child safety ignition system lets you light and adjust burners with one hand.
- The thermocouple safety system automatically stops the gas flow if the flame goes out, even when electrical power is cut.
- The design of the segmented HOBs has been developed so that they suit a kitchen with any series of Bertazzoni appliances.



FEATURES

Brass burners	3
Dual wok (1x)	750-18000 Btu/h
Rapid (1x)	11000 Btu/h
Semi-rapid (1x)	6500 Btu/h
Simmer rate	750 Btu/h
Griddle	800 W
Maintop	stainless steel
Worktop controls	knobs
Knobs	solid metal
Grates	cast iron
One hand ignition	yes
Wok adapter	yes
Griddle dual control	yes

TECHNICAL SPECIFICATIONS

Electrical Requirements	120 V 60 Hz
Max Amp usage, power rating	10 A - 800 W
Certification	CSA
Warranty	2 years parts and labor

ACCESSORIES

Wok ring (standard)	code 408117
Simmer ring (optional)	code 408077

A LP conversion kit for all burners is included



TO COOK BEAUTIFULLY
WWW.BERTAZZONI.COM

INSTALLATION INSTRUCTIONS

PM36 3 0G X

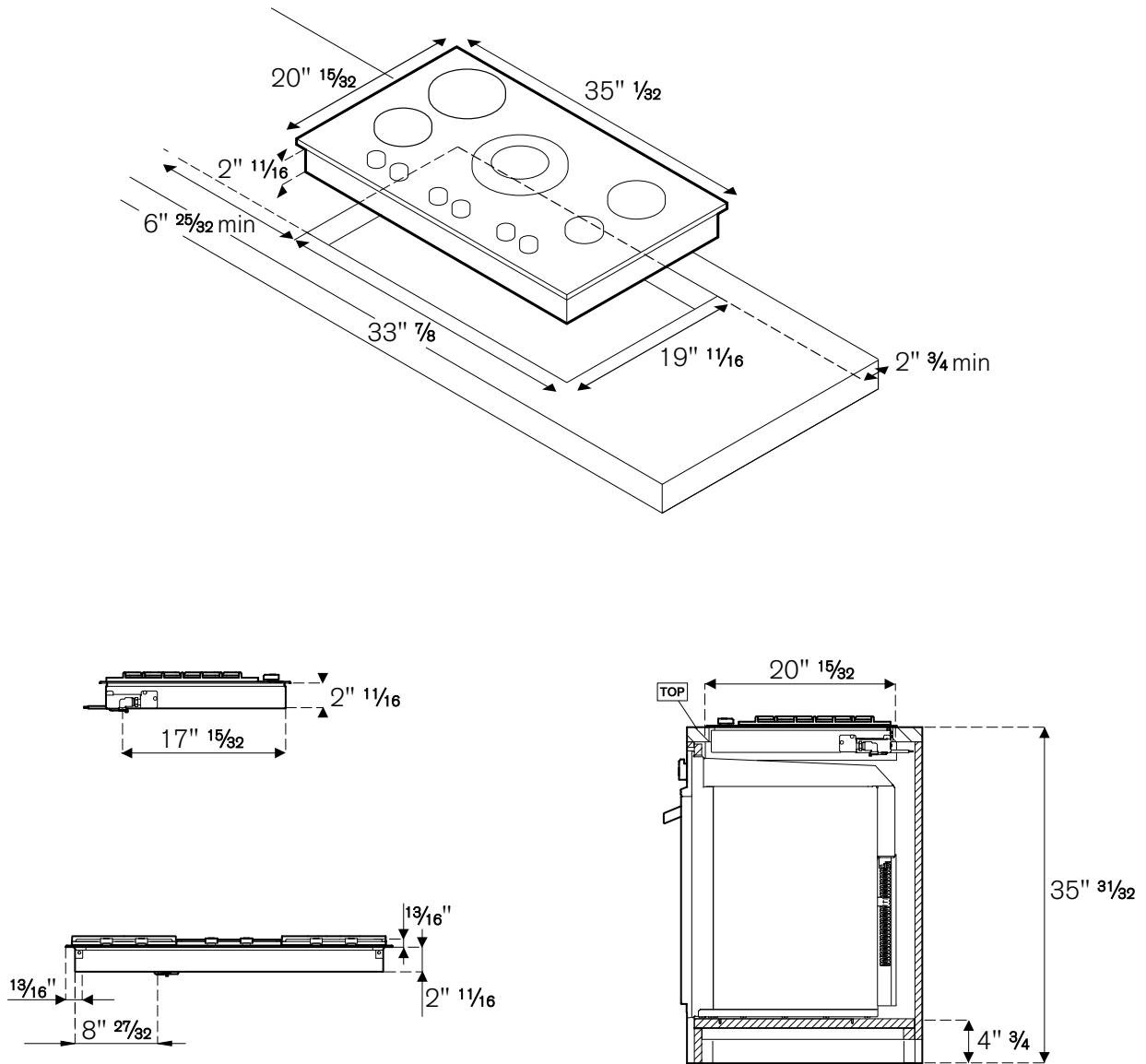

Bertazzoni recommends to operate the appliance after it has been installed in a cabinet. The kitchen cabinets shall be made of materials capable of withstanding temperatures at least 117°F (65°C) above room temperature in order to avoid possible damage to the cabinets during appliance usage. For further installation instructions refer to the installation manual.

Disclaimer: while every effort has been made to insure the accuracy of the information contained in this brochure, Fratelli Bertazzoni reserves the right to change any part of the information at any time without notice.

Fratelli Bertazzoni, Bertazzoni and the winged wheel brand icon are registered trademarks of Bertazzoni Spa.