

60CM (Approx. 24") Built-in Speed Oven  
with 1000W Microwave, Stainless Steel  
EAN13: 8017709219758

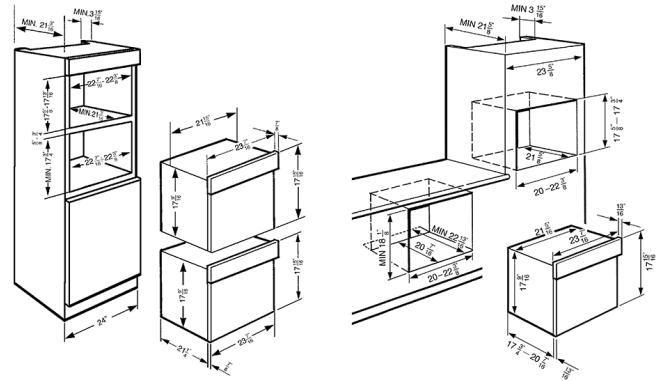

• **Modern Linea Design** • 10 cooking modes • Fingerprint-proof stainless steel finish • Ergonomic control knobs • Stainless steel cavity • Digital LED display • Time-setting options: Start & Stop • End-of-cooking acoustic alarm • Automatic oven/microwave switch-off when door is open • True European convection cooking (can also be combined with microwave) • 12 5/8" size glass turntable • Adjustable temperature: 122–428°F • Cooling fan • Defrost programmed by weight or by time • Microwave pizza cooking function • Child-safe control lock • Microwave screen protection • 1x 20W halogen light (illuminates when door is opened) • Oven capacity: 1.20 cu. ft. • Microwave power: 1,850W • Microwave effective power: 1,000W • Voltage rating: 220v – 60Hz • Connected load (nominal power): 3.40kW • Amps 240V: 20Amps • **Accessories Included:** • 1 large grid • 1 glass tray • 1 special crisp plate

## Functions

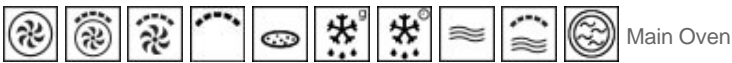

## Options

- CTU15S - Food and Dish Warming Drawer