

# INDUCTION ELECTRIC RANGE

for residential use only



Models: **VEFSIE 304 P..**

---

## INSTALLATION INSTRUCTIONS

### IMPORTANT - PLEASE READ AND FOLLOW

- Before beginning, please read these instructions completely and carefully.
- Do not remove permanently affixed labels, warnings, or plates from the product. This may void the warranty.
- Please observe all local and national codes and ordinances.
- Please ensure that this product is properly grounded.
- **The installer should leave these instructions with the consumer who should retain for local inspector's use and for future reference.**

Electrical installation must be in accordance with the National Electrical Code, ANSI/NFPA70 - latest edition and/or local codes.

IN CANADA: Electrical installation must be in accordance with the current CSA C22.1 Canadian Electrical Codes Part 1 and/or local codes.

Some models are supplied with a protective film on steel and aluminium parts. This film must be removed before installing/using the appliance.

**FOR INSTALLER ONLY**

**THIS RANGE IS FOR RESIDENTIAL USE ONLY**





## WARNING !

To reduce the risk of tipping the appliance, the appliance must be secured by properly installed anti-tip device packed with the appliance.

- ALL RANGES CAN TIP
- INJURY TO PERSONS COULD RESULT
- INSTALL ANTI-TIP DEVICE PACKED WITH RANGE
- SEE INSTALLATION INSTRUCTIONS



## WARNING !



### Health Hazard

Persons with cardiac pacemakers or other electrical implants (such as insulin pumps) must consult with their doctor or implant manufacturer before using this appliance to make sure that their implants will not be affected by the electromagnetic field.

Failure to follow this advice may result in death.

This appliance is designed and manufactured solely for the cooking of domestic (household) food and is not suitable for any non-domestic application and therefore should not be used in a commercial environment.

The appliance warranty will be void if the appliance is used within a non-domestic environment i.e. a semi-commercial, commercial or communal environment.

# INSTALLATION INSTRUCTIONS

## WARNING!

THIS APPLIANCE MUST BE INSTALLED BY A QUALIFIED INSTALLER.

Installation must conform with local codes.



Improper installation, adjustment, alteration, services, or maintenance can cause injury or property damage. Consult a qualified installer or a service agent.



## WARNING!!

**IMPORTANT:** The use of suitable protective clothing/gloves is recommended when handling, installing of this appliance.

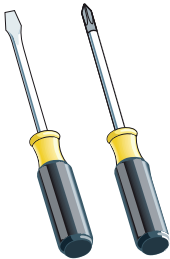
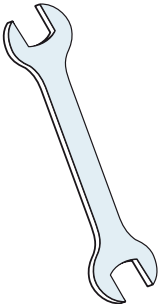
## TOOLS NEEDED FOR INSTALLATION (NOT SUPPLIED WITH THE APPLIANCE)

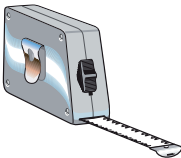
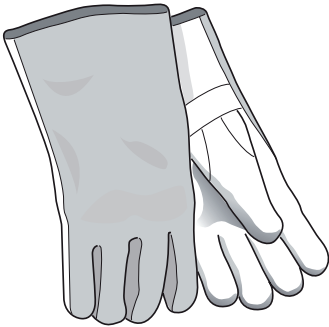
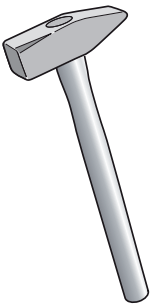
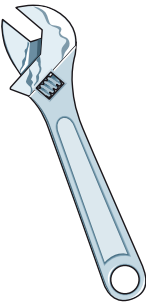
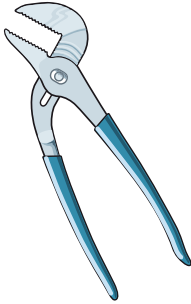
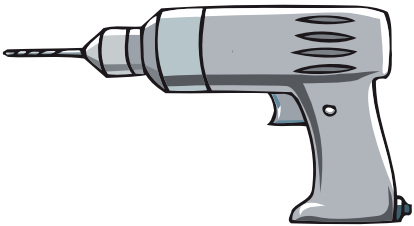
				
Screwdriver	2 - Wrench		Pencil	Tape measure
				
Suitable protective gloves	Hammer	Adjustable wrench	Adjustable pliers	Drill

---

## GENERAL INFORMATION



### **WARNING!!**

1. **This appliance shall not be used for space heating. This information is based on safety considerations.**
2. All openings in the wall behind the appliance and in the floor under the appliance shall be sealed.
3. Keep appliance area clear and free from combustible materials, gasoline, and other flammable vapors.
4. Do not obstruct the flow of ventilation air.
5. Disconnect the electrical supply to the appliance before servicing.
6. When removing appliance for cleaning and/or service;
  - A. Disconnect AC power supply.
  - B. Carefully remove the range by pulling outward.  
**CAUTION:** Range is heavy; use care in handling.
7. **Electrical Requirement**  
Electrical installation should comply with national and local codes.
8. The misuse of oven door (e.g. stepping, sitting, or leaning on them) can result in potential hazards and/or injuries.
9. When installing or removing the range for service, a rolling lift jack should be used. Do not push against any of the edges of the range in an attempt to slide it into or out of the installation. Pushing or pulling a range (rather than using a lift jack) also increases the possibility of bending the leg spindles or the internal coupling connectors.



### **WARNING!!**

#### **ELECTRICAL GROUNDING INSTRUCTIONS**

The range must be electrically grounded in accordance with local codes or, in the absence of local codes, with the National Electrical Code, ANSI/NFPA No. 70-latest edition, in Canada Canadian Electrical Code. Installation should be made by a licensed electrician.

**Installation should be made by a licensed electrician.**

**FOR PERSONAL SAFETY, THIS APPLIANCE MUST BE PROPERLY GROUNDED.**

If an external electrical source is utilized, the installation must be electrically grounded in accordance with local codes or, in the absence of local codes, with the national Electrical Code, ANSI/NFPA 70.

#### **REPLACEMENT PARTS**

Only authorized replacement parts may be used in performing service on the range. Replacement parts are available from factory authorized parts distributors. Contact the nearest parts distributor in your area.

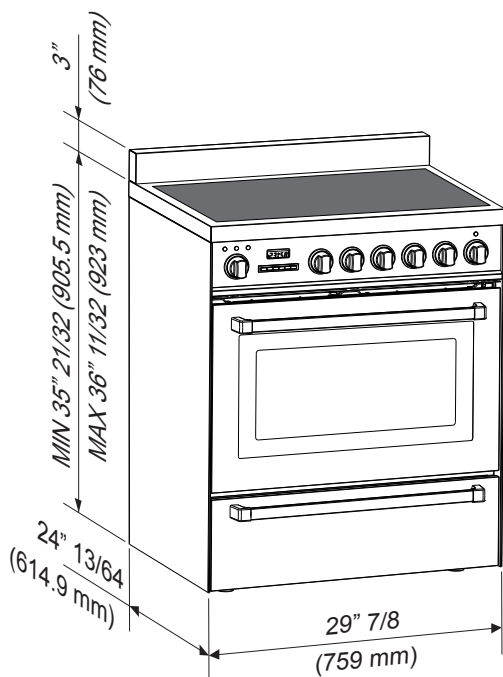

Fig. 1.1

## PROXIMITY TO SIDE CABINETS

1. This range may be installed directly adjacent to existing 36" (914 mm) high base cabinets.

Range dimensions:

- width: 29" 7/8 (759 mm)
- depth: 24" 13/64 (614.9 mm)
- height (without backguard): MIN 35" 21/32 (905.5 mm) - MAX 36" 11/32 (923 mm)
- backguard (height): 3" (76 mm)

**Grounded outlet:** should be located from the left to the right side of the range; from 5" 7/16 (138 mm) to 6" 1/8 (155.5 mm) [depending on feet regulation] from the floor.

2. The range CANNOT be installed directly adjacent to sidewalls, tall cabinets, tall appliances, or other side vertical surfaces above 36" (914 mm) high.

There must be a minimum of 2" (50 mm) side clearance from the range to such combustible surfaces TO THE LEFT or TO THE RIGHT above the 36" (914 mm) high countertop.

**IMPORTANT: One side (left or right) above the 36" (914 mm) high countertop must always be kept clear.**

**Island installation:** There must be a minimum of 12" (305 mm) clearance from the rear of the backguard to such combustible surface on the back of the range above the 36" (914 mm) high countertop.

3. The maximum upper cabinet depth recommended is 13" (330 mm). Wall cabinet above the range must be a minimum of 30" (762 mm) above the countertop for a width of minimum 30" (762 mm); it has to be centered with the range. Side wall cabinets above the range must be a minimum of 18" (457 mm) above the countertop.

**ELECTRIC CONNECTION**

Dotted line showing the position of the range when installed

Ref.	inch	mm
A	5" 7/16 - 6" 1/8 (*)	138 - 155.5 (*)

(\*) : Depending on feet regulation

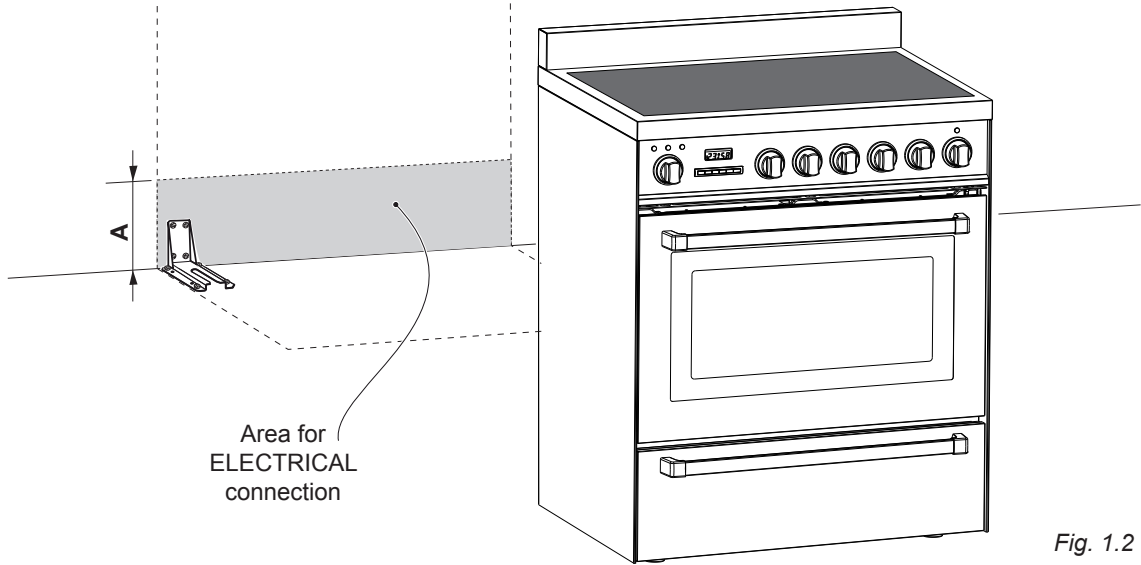

Fig. 1.2

**ASSEMBLING THE BACKGUARD**  
It is mandatory to install the backguard.

Assemble the backguard as shown in figure 1.3:

- Screw the 2 screws "A" interposing the spacers.
- Screw the central screw "B".

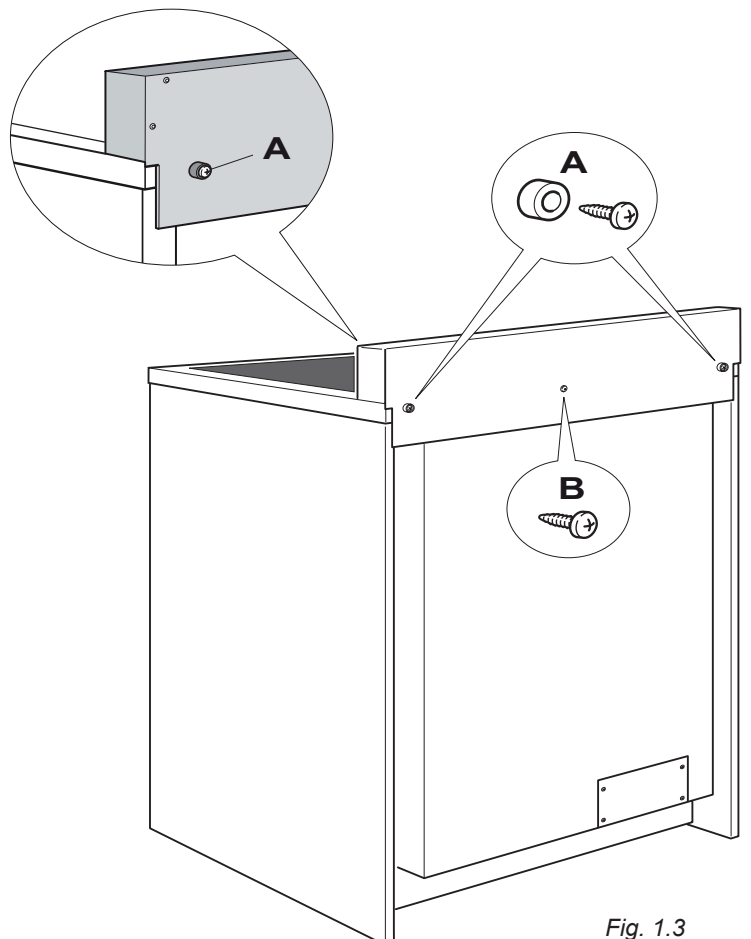
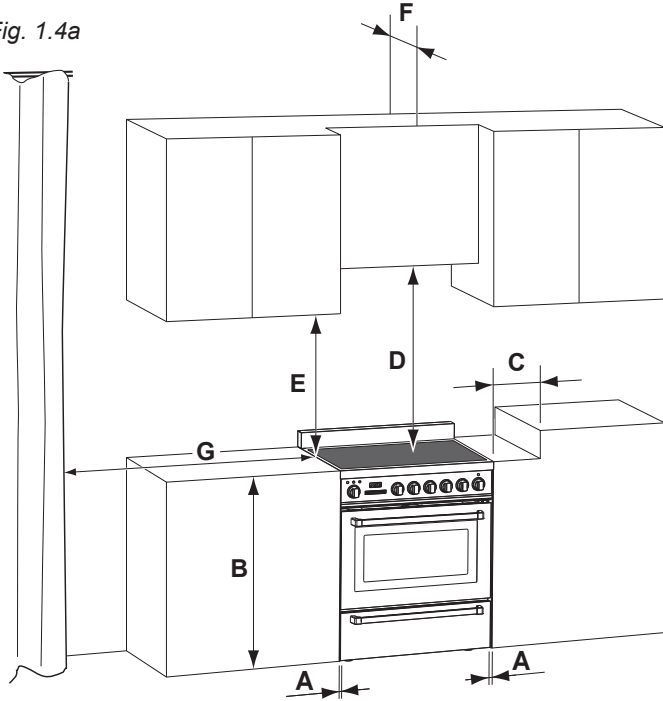

Fig. 1.3

**PROXIMITY TO SIDE CABINETS  
STANDARD INSTALLATION**

Fig. 1.4a



Ref.	inch	mm
A	0"	0
B	36"	914
C	2"	50
D	30" minimum	762 minimum
E	18" minimum	457 minimum
F	13" maximum	330 maximum
G	20" minimum	500 minimum

Fig. 1.4b

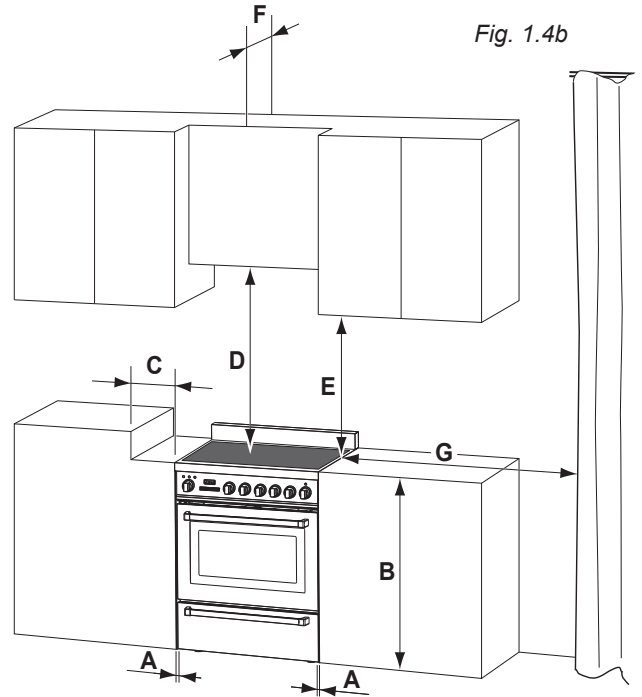



**PROXIMITY TO SIDE CABINETS  
ISLAND INSTALLATION**

Fig. 1.5a

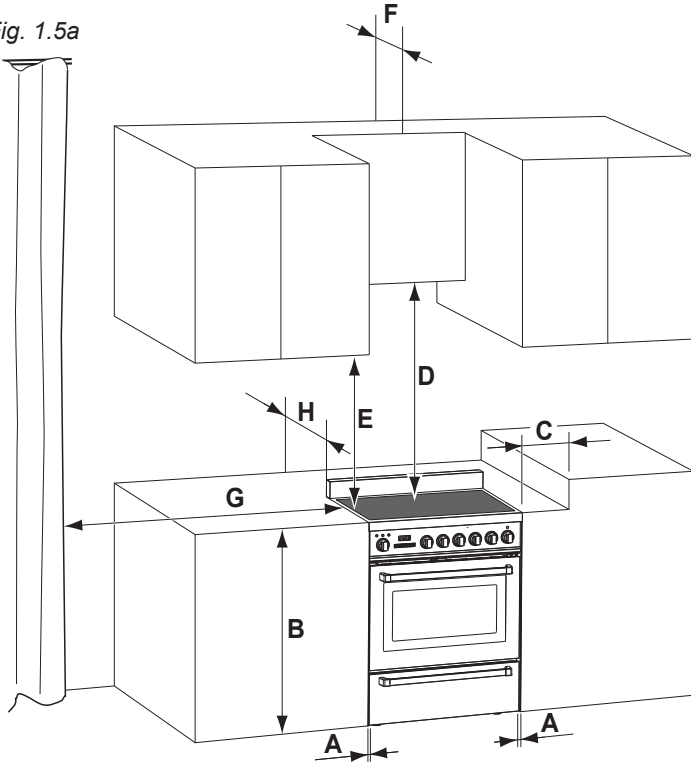

Ref.	inch	mm
A	0"	0
B	36"	914
C	2"	50
D	30" minimum	762 minimum
E	18" minimum	457 minimum
F	13" maximum	330 maximum
G	20" minimum	500 minimum
H	12" minimum	305 minimum

Fig. 1.5b

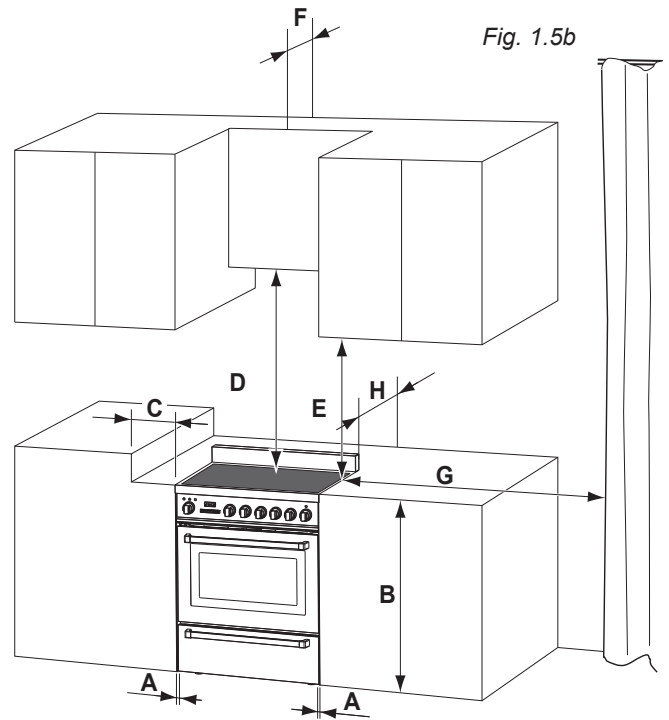

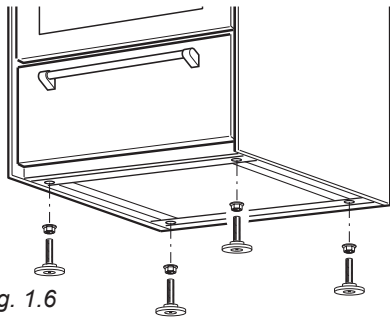

Fig. 1.6

### LEVELLING THE RANGE

The range is equipped with 4 LEVELLING FEET and may be levelled by screwing or unscrewing the feet (figs. 1.6 - 1.7).

It is important to observe the directions of figures 1.6, 1.8a, 1.8b.

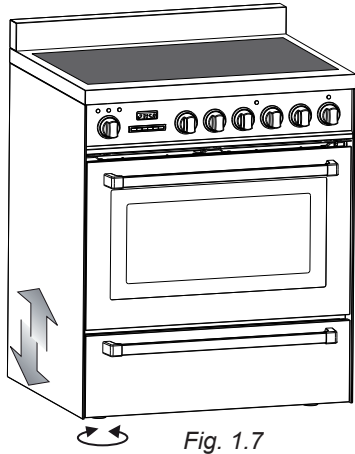

Fig. 1.7

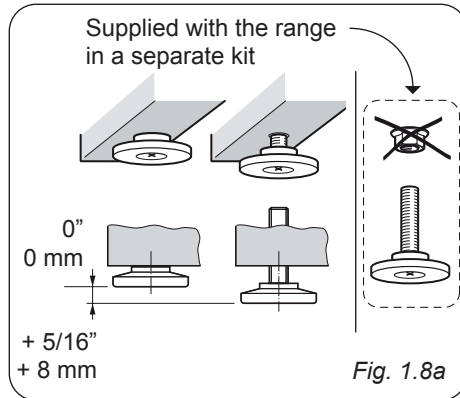

Fig. 1.8a

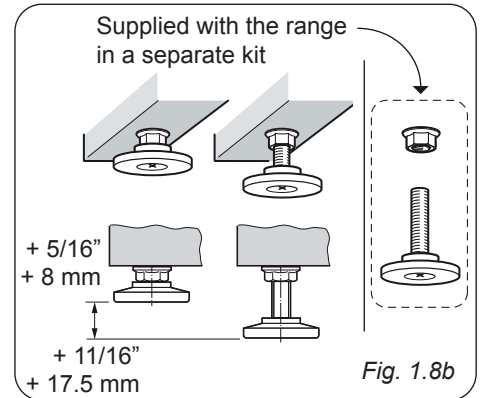

Fig. 1.8b

**YOU MUST USE STABILITY ANTI TIP BRACKET TO PREVENT UNIT FROM TIPPING.**

### ANTI-TIP STABILITY DEVICE INSTALLATION INSTRUCTIONS

1. The anti-tip bracket has to be attached as shown on figure below (only rear left side), it has to be fixed on the floor OR on the rear wall by no. 4 (four) suitable screws (not supplied). Alternatively the anti-tip bracket can also be fixed on the floor AND on the rear wall by no. 8 (eight) suitable screws (not supplied).
2. After fixing the anti-tip bracket, slide range into place. Be sure the rear left foot slides under the anti-tip bracket attached.

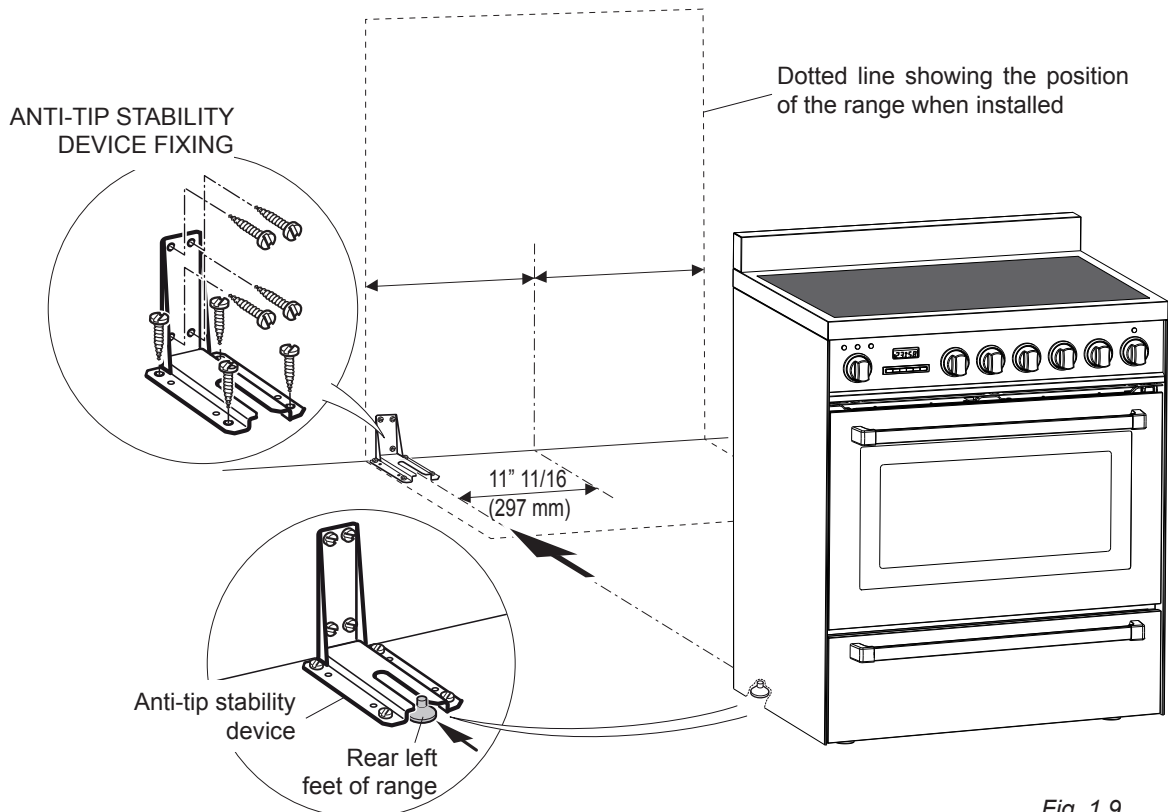

Fig. 1.9

## ELECTRICAL REQUIREMENTS

- This appliance must be properly installed and grounded by a qualified technician in accordance with the National Electrical Code ANSI/NFPA No.70 (latest edition) and local electrical code requirements. IN CANADA: Electrical installation must be in accordance with the current CSA C22.1 Canadian Electrical Codes Part1 and/or local codes.
- This appliance may be connected by means of permanent “Hard Wiring” or “Power Supply Cord Kit”. Power supply cord is not supplied, but it is available through your local electric supply house.
- Use only 3-conductor or 4-conductor CSA/UL listed range cord rated at 50 amps with 250 V minimum and provided with ring terminals. These cords should be provided with strain relief or conduit connector.

**Warning:** Frame grounded through neutral lead. If used in,

- New branch-circuit installations (1996 NEC),
  - Mobile homes,
  - Recreational vehicles, or
  - In an area where local codes prohibit grounding through neutral, use a 4 conductor cord or conduit.
- The range must be connected to the proper electrical voltage and frequency as specified on the rating plate.
  - The range can be connected directly to the fused disconnect (or circuit breaker box) through flexible, armoured or non-metallic sheathed, copper cable (with grounding wire). Allow two to three feet of slack in the line so that it can be moved if servicing is ever necessary.

## Voltage and Power Consumption

AC 120/240 V	60 Hz	10950 W MAX	46 A MAX
AC 120/208 V	60 Hz	10100 W MAX	48.84 A MAX

## ELECTRICAL CONNECTION WITH POWER CORD

Use a 3-wire power supply cord kit rated for 50 amps - 125/250 volts with closed loop terminals and marked for use with ranges. Where local codes do not permit grounding through neutral, use a 4-wire power supply cord kit.

The cord must be secured to the range with a suitable strain relief. The electrical connection is made at the terminal block, which is located behind the terminal block access plate on the back of the range.

## ELECTRICAL CONNECTION WITH CONDUIT

Use 3/4" trade size CSA/UL-listed conduit with a conduit clamp, 10 AWG/600 volt copper conductor colored red for line 1 and black for line 2 and 12 AWG/600 volt copper conductor (or 10 AWG/600 Volt copper conductor if grounding through neutral) colored white for neutral with closed loop terminals marked for use with ranges.

Where local codes do not permit grounding through neutral, use a green 10 AWG copper conductor as directed in the 4-wire connector directions. The conduit must be secured to the range with the strain relief bracket. The electrical connection is made at the terminal block which is located behind the terminal block access plate on the back of the range.



**WARNING**

**TO AVOID ELECTRICAL SHOCK HAZARD, BEFORE INSTALLING THE APPLIANCE, SWITCH POWER OFF AT THE SERVICE PANEL AND LOCK THE PANEL TO PREVENT THE POWER FROM BEING SWITCHED ON ACCIDENTALLY.**



**WARNING!!**



**Electrical Shock Hazard**  
Electrically ground range. Failure to follow these instructions can result in death, fire, or electrical shock.

Location of Nameplate

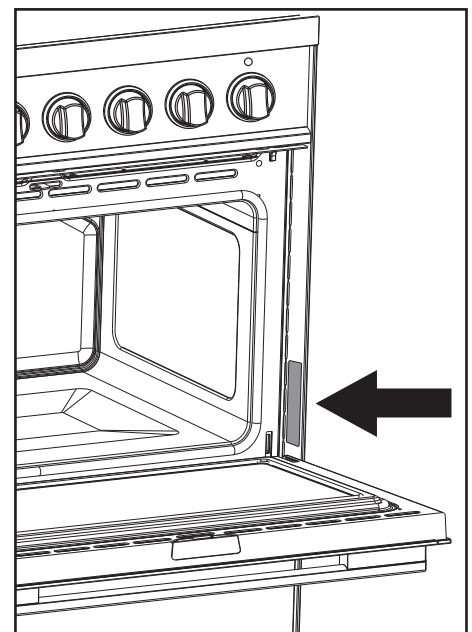

### 3-Wire Power Cord Installation (See figures 2.1, 2.2)

1. Remove the **Terminal Block Access Plate** on the back of the range by unscrewing the 4 fixing **Screws** (figure 2.1).
2. Check the correct positioning of the **Power Cord Bracket** as per figure 2.2.
3. Insert the **Power Cord** through the hole in the **Power Cord Bracket**; then tighten the **Power Cord** by using a suitable **Strain Relief**. Allow enough slack to easily attach the cord terminals to the **Terminal Block**.
4. Remove the 3 wire terminal nuts and washers from the **Terminal Block**.
5. Plug the terminal holes of **Power Cord**. The **Neutral or Ground Wire** of the **Power Cord** must be connected to the neutral terminal located in the center of **Terminal Block**. The **Power Wires** must be connected to the outside terminals.
6. Plug washers and tighten nuts securely.



Do not remove **Ground strap**.

7. Assemble the **Terminal Block Access Plate**.

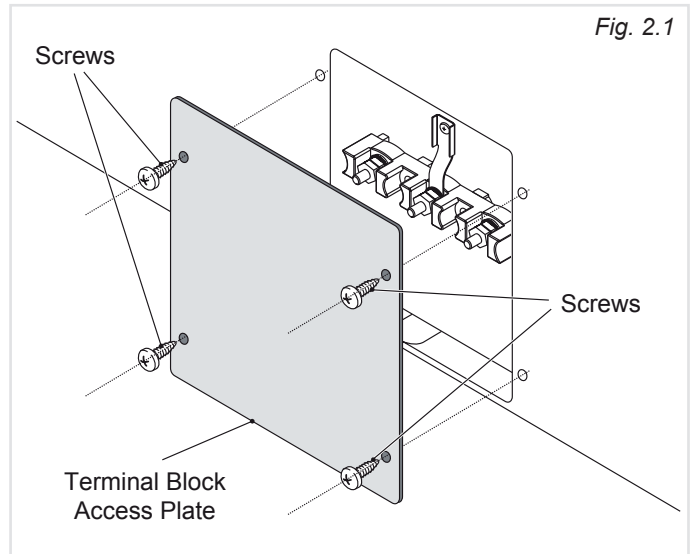

Fig. 2.1

### 4-Wire Power Cord Installation (See figure 2.1, 2.3)

1. Remove the **Terminal Block Access Plate** on the back of the range by unscrewing the 4 fixing **Screws** (figure 2.1).
2. Check the correct positioning of the **Power Cord Bracket** as per figure 2.3.
3. Insert the **Power Cord** through the hole in the **Power Cord Bracket**; then tighten the **Power Cord** by using a suitable **Strain Relief**. Allow enough slack to easily attach the cord terminals to the **Terminal Block**.
4. Remove the 3 wire terminal nuts and washers from the **Terminal Block**.
5. Remove the **Ground Strap** from the frame of range and terminal by removing its screw and cutting it as shown in figure 2.3.
6. Plug the terminal holes of **Power Cord**.

The **Neutral Wire** of the **Power Cord** must be connected to the neutral terminal located in the center of **Terminal Block**; the **Power Wires** must be connected to the outside terminals; the **Ground Wire** must be attached to the frame of range by using the  $\perp$  (Ground) identified **Grounding Screw**.

7. Plug washers and tighten nuts securely.
8. Assemble the **Terminal Block Access Plate**.

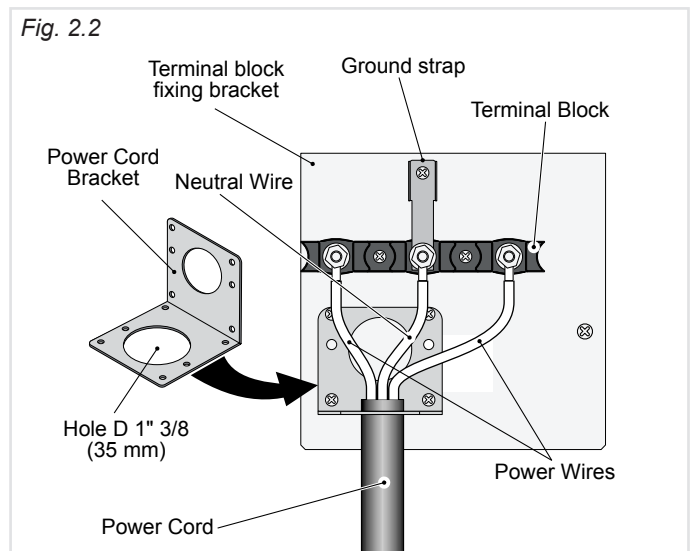

Fig. 2.2

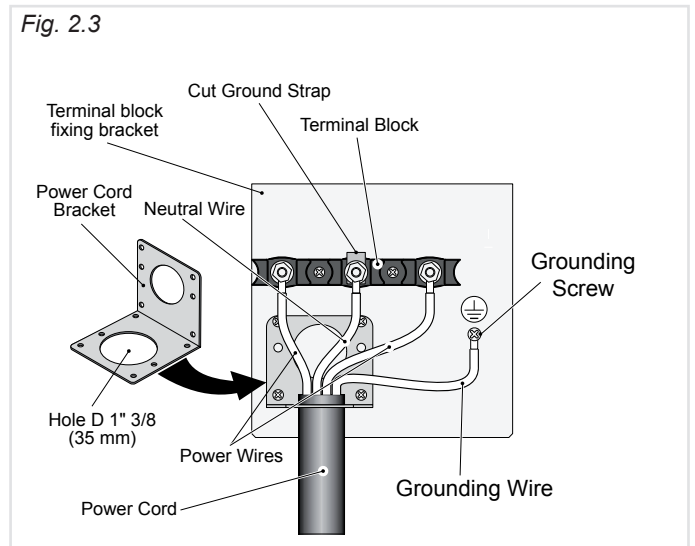

Fig. 2.3

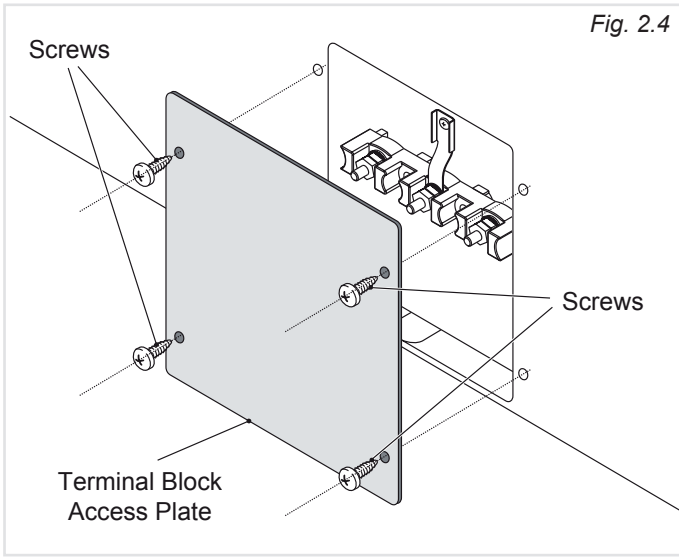



Fig. 2.4

**3-Wire Conduit Installation** (See figures 2.4 and 2.5)

1. Remove the **Terminal Block Access Plate** on the back of the range by unscrewing the 4 fixing **Screws** (figure 2.4).
  2. Check the correct positioning of the **Conduit Bracket** as per figure 2.5.
  3. Feed 3/4" trade size **Conduit** through the hole in the **Conduit Bracket** and secure to the **Conduit Bracket** with a **Conduit Clamp**.
  4. Remove the 3 wire terminal nuts and washers from the **Terminal Block**.
  5. Plug the terminal holes of conductors.  
The **Neutral or Ground Wire** of the **Power Cord** must be connected to the neutral terminal located in the center of **Terminal Block**.  
The **Power Wires** must be connected to the outside terminals.
  6. Plug washers and tighten nuts securely.
-  Do not remove **Ground strap**.
7. Assemble the **Terminal Block Access Plate**.

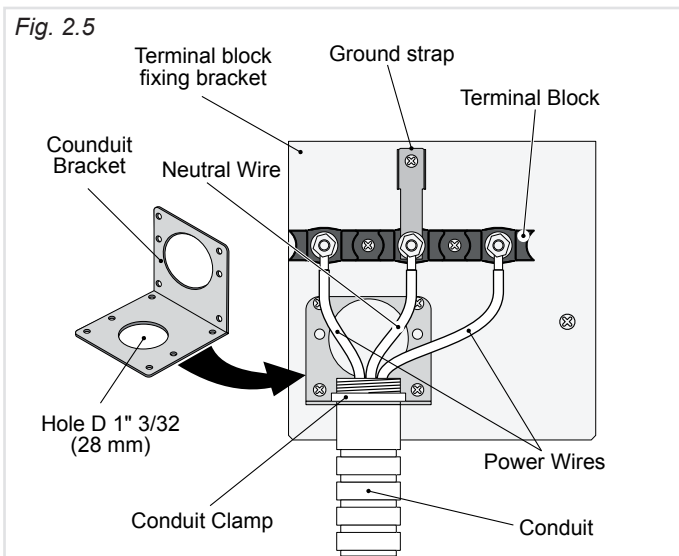

Fig. 2.5

**4-Wire Conduit Installation** (See figure 2.4 and 2.6)

1. Remove the **Terminal Block Access Plate** on the back of the range by unscrewing the 4 fixing **Screws** (figure 2.4).
2. Check the correct positioning of the **Conduit Bracket** as per figure 2.6.
3. Feed 3/4" trade size **Conduit** through the hole in the **Conduit Bracket** and secure to the **Conduit Bracket** with a **Conduit Clamp**.
4. Remove the 3 wire terminal nuts and washers from the **Terminal Block**.
5. Remove the **Ground Strap** from the frame of range and terminal by removing its screw and cutting it as shown in figure 2.6.
6. Plug the terminal holes of conductors.  
The **Neutral Wire** of the **Power Cord** must be connected to the neutral terminal located in the center of **Terminal Block**; the **Power Wires** must be connected to the outside terminals; the **Ground Wire** must be attached to the frame of range by using the  $\perp$  (Ground) identified **Grounding Screw**.
7. Plug washers and tighten nuts securely.
8. Assemble the **Terminal Block Access Plate**.

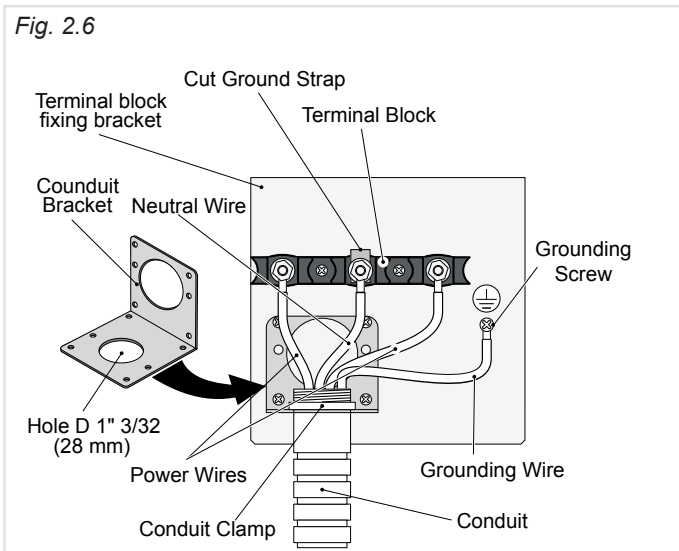
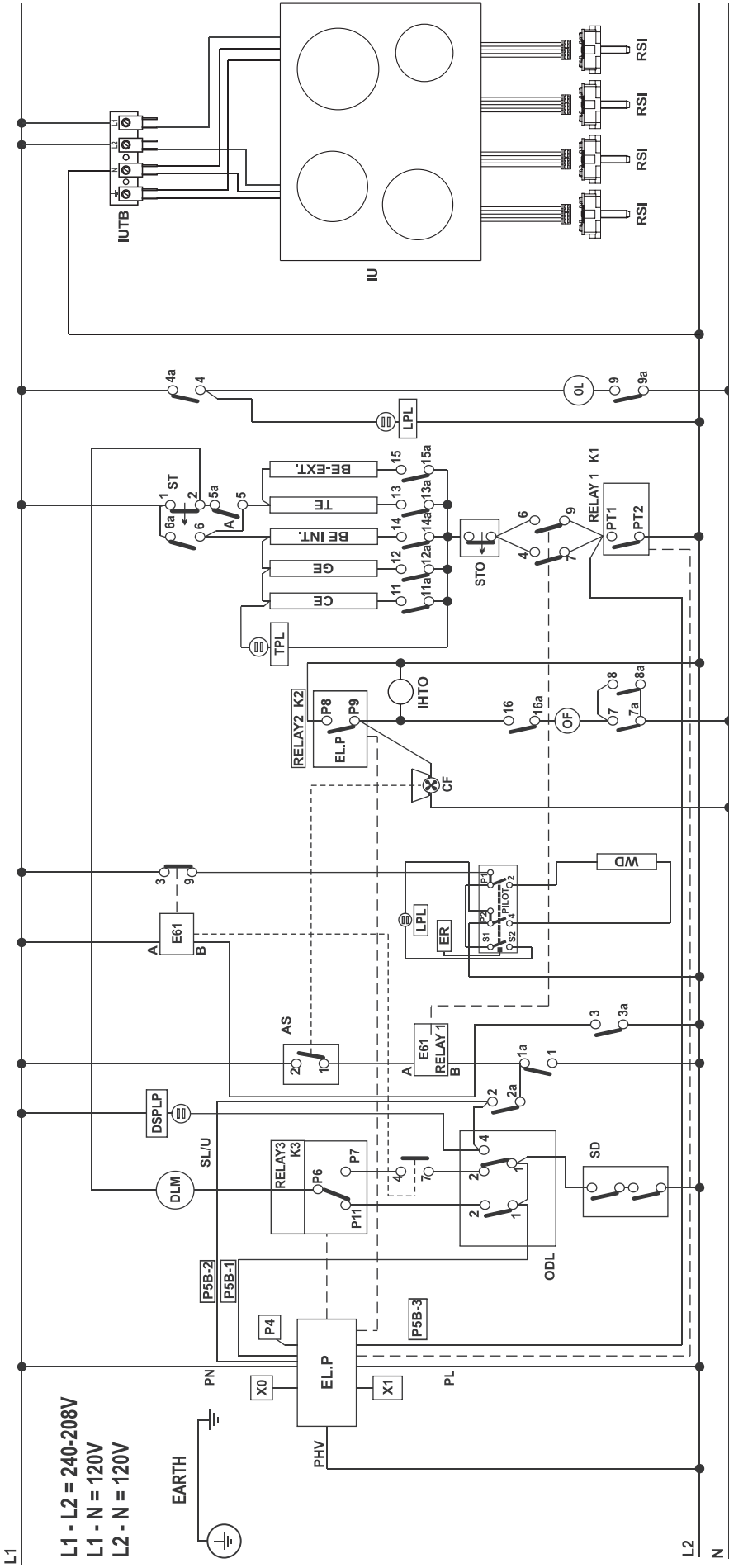

Fig. 2.6

WIRING DIAGRAM



ELECTRIC DIAGRAM KEY

- IU INDUCTION UNIT
- RSI ROTARY SELECTOR INTERFACE
- IUTB INDUCTION UNIT TERMINAL BLOCK
- IHTO INDUCTION HOBB THERMAL OVERLOAD
- OL OVEN LAMP
- E61 RELAY
- CE CIRCULAR ELEMENT
- GE BROIL ELEMENT
- TE TOP ELEMENT
- BE-INT BOTTOM ELEMENT INT.
- BE-EXT BOTTOM ELEMENT EXT.
- TPL THERMOSTAT PILOT LAMP
- DSPLP DOOR SAFETY PILOT LAMP
- CF COOLING FAN
- OF OVEN FAN
- ER ENERGY REGULATOR
- DLM DOOR LOCK MOTOR
- SL/U STATUS LOCK/UNLOCK

- LPL LINE PILOT LAMP
- WD WARMING DRAWER ELEMENT
- ST SAFETY THERMOSTAT
- EL.P ELECTRONIC PROGRAMMER
- SD DOOR STATUS, OPEN/CLOSED
- ODL OVEN DOOR LATCH
- AS AIR SWITCH

CONNECTIONS ON PROGRAMMER

- PN/PL SUPPLY
- K1 PROGRAM THERMOSTAT RELAY1
- K2 COOLING/OVEN FAN RELAY2
- K3 DOOR LOCK/UNLOCK RELAY3
- PHV FUNCTION STATE
- X0 THERMOSTAT ENCODER
- X1 FUNCTIONS ENCODER
- P4 DOOR LOCK MOTOR
- P5B WIRES P5B(1)+P5B(2)+P5B(3)



The manufacturer cannot be held responsible for possible inaccuracies due to printing or transcription errors in the present booklet.

The manufacturer reserves the right to make all modifications to its products deemed necessary for manufacture or commercial reasons at any moment and without prior notice, without jeopardising the essential functional and safety characteristics of the appliances.