



TOP PERFORMANCE



HUSH SYSTEM



CFM REDUCTION



DIM LIGHT



LED LIGHT



TOUCH CONTROL

ELICA'S EXCLUSIVE PLUS FEATURES

Black panel and polished stainless steel, Foglia features a gently arched front that softens the units profile and provides an angled panel for easy access to the controls.

Available in 30" & 36" widths, Foglia includes a powerful 600 CFM blower, LED lighting with dimmable feature, stainless steel microhole filters and capacitive touch controls that deliver convenience and safety.

Designed for standard ducted installation, Foglia can also be installed as a recirculating system using the Recirculating Kit, available as an accessory.

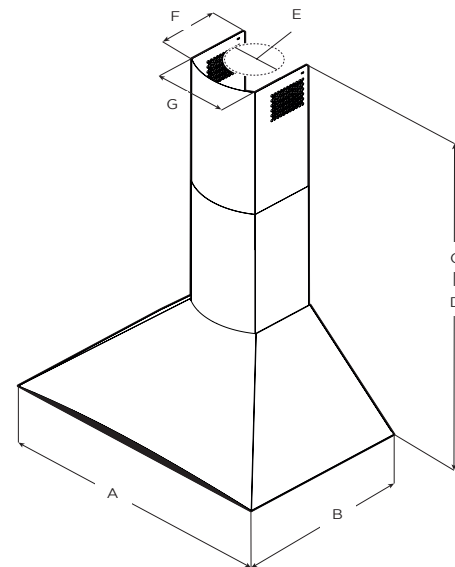

≥27"



≥30"

MOUNTING HEIGHT RANGE

	Models	
	EFG630S1	EFG636S1
A	30" (76.2 cm)	36" (91.4 cm)
B	19 <sup>11</sup> / <sub>16</sub> " (50 cm)	
C*	Max: 42 <sup>1</sup> / <sub>8</sub> " (107 cm) Min: 28 <sup>5</sup> / <sub>16</sub> ** (73 cm)	
D**	Max: 38 <sup>5</sup> / <sub>16</sub> " (97 cm) Min: 28 <sup>5</sup> / <sub>16</sub> " (73 cm)	
E	6" (15.24 cm)	
F	8" (20.5 cm)	
G	8 <sup>5</sup> / <sub>16</sub> " (21.5 cm)	

\* Ductless (Recirculating) version  
\*\* Ducted version

SPECIFICATIONS



	30" UNIT	36" UNIT
Model:	EFG630S1	EFG636S1
Dimensions:	30"W x 20"D x 10"H	36"W x 20"D x 10"H
Blower Type(internal):	600 CFM, 4-Speed Internal	
Blower Performance:		
Speed 1	210 CFM	
Speed 2	300 CFM	
Speed 3	470 CFM	
Speed 4	600 CFM	
Noise (sones): Working Speed	Min: 1.71, Max: 7.5	
Finish:	Stainless Steel + Black Glass	
Controls:	Touch Control 3S+ Booster	
Illumination:	2 Premium LED Dimmable Lights, 2.5 W	
Filter Type:	Dishwasher- Safe, Stainless Steel Microhole Filter	
Installation Type:	Ducted or Recirculating with installation Kit (sold separately)	
Telescopic Chimney	For heights 7'1" - 9'1" (ducted)	
Extension:	For heights 7'5" - 9'6" (recirculating)	
Duct Transition:	6" Round with Back Draft Damper (top)	
Electrical:	120V-60Hz, 455 Watts at 3.8 Amps	
<b>KITS:</b>		
Optional Recirculating Kit	KIT02766	
Chimney Extension Kit Reaches 8'5" - 11'3" (ducted), 8'7" - 11'7" (recirculating)	KIT02784	
<b>CONSUMABLE PARTS</b>		
Replacement Grease Filter (1)	GF04YB	
Replacement Carbon Filter (1)	KIT02667	
Replacement Light Bulb (1)	2006BH	

\*Consumable parts are sold in units of one (1). Order accordingly

\*The product images shown are for illustration purposes only and may not be an exact representation of the product.

PLUS FEATURES



**TOP PERFORMANCE** - Excellent performance for models equipped with this plus. High fume capturing capacity with an average aspiration range of 600 CFM's. with low noise levels, 1.2 - 1.7 sones at working speed.



**HUSH SYSTEM** - An exclusive sound deadening technology that effectively reduces sound levels up to 35%, compared to typical range hoods.



**CFM REDUCTION** - CFM Reduction System (CRS), is an exclusive feature to Elica hoods, which enables the user to reduce directly in the glass touch control the maximum blower CFM, to meet local code requirements.



**DIM-LIGHT** - The Dimmer allows you to adjust the brightness of the light as you wish. With Elica, lighting is customized in a discreet, personal and practical way, in order to contribute in creating the perfect kitchen atmosphere.



**LED LIGHT** - LED lighting is undoubtedly the smartest solution in terms of energy saving. Expected life time of over 20.000 hours, represents the most remarkable advantage of LED light bulbs.



**ELECTRONIC TOUCH CONTROLS** - Enjoy the modern design and convenience of multi-function electronic touch controls, which are discreetly hidden behind sleek black glass, and will illuminate a soft blue when activated.