

- Produces up to 25 lbs of ½" x ⅞" x 2 ⅜" crescent cubes per day
- Removable ice storage bin holds up to 20 lbs of crescent cubes
- Clear ice scoop and storage hook included
- Matte black prepainted cabinet exterior
- Black interior
- Mechanical thermostat control
- Auto shut-off when ice bin is full
- Unit ships right hinged with field-reversible door
- Door close assist hinge ensures door closure
- Model includes a ¾" diameter horizontal stainless steel handle
- Precise zero clearance design allows for unmatched integration into any built-in setting
- 4 Independent adaptable leveling feet
- Fixed stainless steel grille design allows alignment with adjacent cabinetry and toe kick/plinth
- Perfect for indoor and outdoor applications



Model Details

Model	Pump	Finish	Description	Shipping Weight
SCIM153SS	No	Stainless Steel	15" Indoor/Outdoor Premium Crescent Cube Ice Maker	108 lbs

Dimensions/Weight	Detail
Product Depth	21 1½"
Product Height	33 ¾" - 34 ¾"
Product Width	14 ⅞"
Product Weight	62 lbs
Shipping Dimensions	17 ¼" x 26 ½" x 35 ¼"
Shipping Weight	108 lbs



*Refer to manual for all panel and installation instructions

The Legacy Companies warrants to the original purchaser of its SAPPHIRE products that they will be free from defects in materials and workmanship for the following time periods from the date of purchase shown on the sales receipt:

Two (2) Years Parts & On-Site Labor | Five (5) Years Compressor Warranty (Parts Only)

See complete warranty for details.



SapphireAppliances.com | 1.866.754.6672
The Legacy Companies

3355 Enterprise Avenue, Suite 160, Fort Lauderdale, FL 33331

Model	Details
Control Type	Mechanical Thermostat Control
Indoor or Outdoor	Indoor/Outdoor
Built-in Installation	Inset, Frameless
Ice Size	½" x ⅞" x 2 ⅝"
Ice Weight (g) per unit	15 g / 0.033 lbs
Ice Quantity per cycle	12 per Slab (-- lb)
Ice Production Capacity	25 lbs
Ice Storage Capacity	20 lbs
Refrigerant Type	R600a

Plumbing Water	Details
Water Inlet Adapter	¼" OD Compression Fitting*
Water Pressure Operating Range (psi)	20 psi - 80 psi
Integrated Water Filter System	No
Water Usage	12 ½ gallons per 100 lbs of ice
Factory Installed Drain Line	Not required
Drain Required	Not required

*Water line not included

Electrical	Details
Electrical Requirements	115 V / 60 Hz
Volt Range	104 V ~ 127 V
Electrical Service	15 amp
Running Amps	1.9 amps

Approvals - Certifications	Details
UL Commercial	Yes

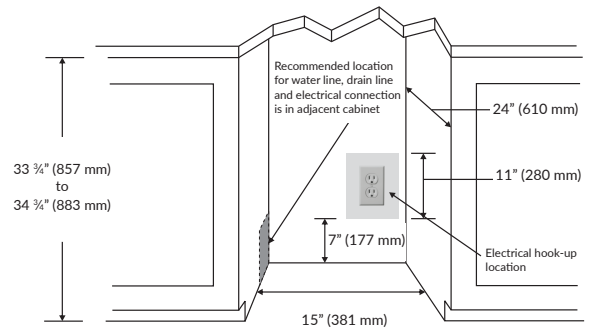

NOTE: For Gravity drain models, the drain hole cannot exceed 7 inches above the floor. For Pump models, the drain hole should be no lower than 7 inches and no higher than 4 feet above the floor.

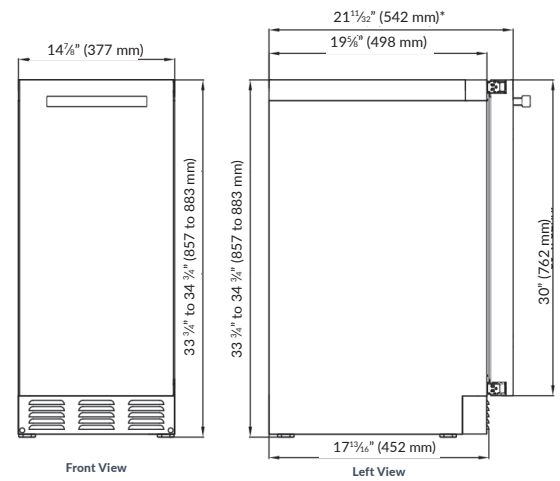

*Dimensions are the same for Panel Ready unit when ¾" panel applied

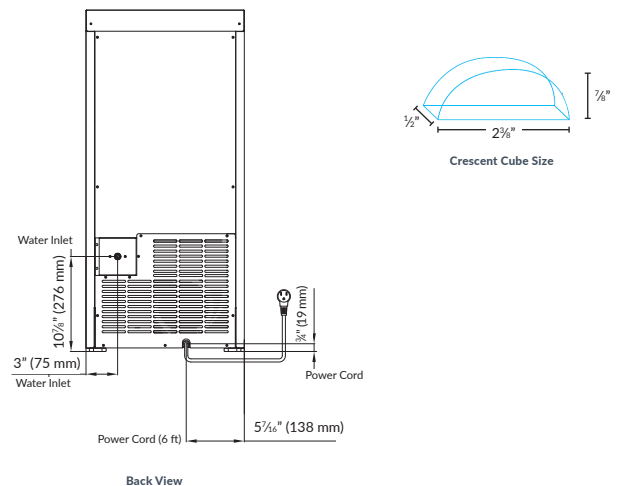

The Legacy Companies warrants to the original purchaser of its SAPPHIRE products that they will be free from defects in materials and workmanship for the following time periods from the date of purchase shown on the sales receipt:

Two (2) Years Parts & On-Site Labor | Five (5) Years Compressor Warranty (Parts Only)

See complete warranty for details.

SapphireAppliances.com | 1.866.754.6672
The Legacy Companies

3355 Enterprise Avenue, Suite 160, Fort Lauderdale, FL 33331

SAPSS20
080823