

# IKE6401BT

AEG

## 24" Built-In Induction Cooktop

### FEATURES & BENEFITS

#### Blends Seamlessly Into Any Kitchen

The black surface and stainless steel trim aligns perfectly with every kitchen style.

#### Induction Elements

Electromagnetic heating technology where heat is generated inside your cookware, ensuring a more efficient process with less energy waste, faster heating, and a safer cooking experience.

#### Ceramic Glass Surface

Ensures improved safety and easy cleaning.

#### Touch & Slide Controls

Adjust and control the power levels with a simple touch and slide design.

#### Digital Timer Setting

The digital timer setting of up to 99 minutes helps coordinate meal preparation and cooking.

#### 9 Power Levels

Allow you to adjust the heat output of each element.

#### Residual Heat Indicator

Cooktop indicates when elements are still hot.

#### Automatic Switch-Off

The cooktop automatically turns off when overheating.

### AVAILABLE COLORS

● Stainless Steel / Black Glass Finish

### GENERAL PROPERTIES

Type	24" Induction Cooktop
Style	Built-In
Surface Colour	Black
Frame Colour	Metal Aluminum Frame (Four Sides)
Beveled Edge	Beveled Edges (Four Sides)

### CONTROL FEATURES

Cooktop Control Type	Touch & Slide Controls
Control Location	Front - Right

### COOKTOP FEATURES

Number of Zones	4 Cooking Zones
Lighted Icons	Red - LED Light
Bridge Cooking Element	Yes
Power Stage Setting	0-9 Power Levels
Digital Timer Setting	00 - 99 minutes
Residual Heat Indicator	Yes
Automatic Safety Shut Off	Yes
Pause Function	Yes
Automatic Safety Switch Off	Yes
Child Lock Function	Yes

### ELEMENT PERFORMANCE

Total Surface Element Wattage	7200 W
Zone / Power Boost Watts – Front Right	1200 W / 1500 W
Zone / Power Boost Watts – Front Left	2000 W / 2600 W
Zone / Power Boost Watts – Rear Right	1800 W / 2300 W
Zone / Power Boost Watts – Rear Left	2000 W / 2600 W
Bridge Zone / Power Boost Watts - Left	3600 W

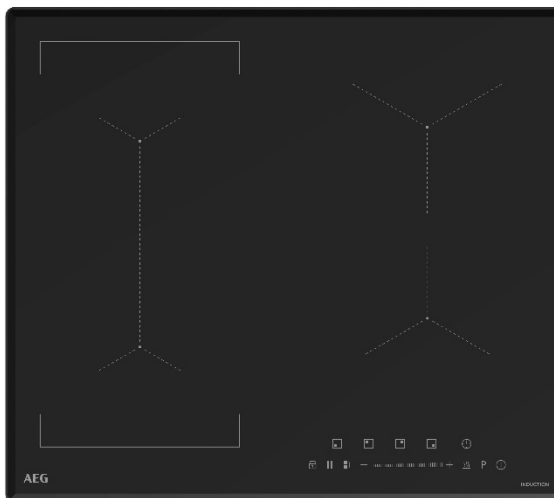

### ELEMENT SIZE

Diameter of Cooking Zones - Front Right	6" (152mm)
Diameter of Cooking Zones - Front Left	8.5" x 8.5" (216 x 216mm)
Diameter of Cooking Zones - Rear Right	7" (177mm)
Diameter of Cooking Zones - Rear Left	8.5" x 8.5" (216 x 216mm)
Diameter of Cooking Zones - Bridge Zone	8.5"-17" (216mm - 431mm)

### TECHNICAL DETAILS

Watts (W)	7200 W
Volts (V)	208/240 V
Frequency (Hz)	60 Hz
Amperage (Amp)	40
Power Cord Length	51" (1300mm)

### DIMENSIONS

Product Dimensions (In / mm) (W / H / D)	23 <sup>1/4"</sup> / 3 <sup>9/16"</sup> / 20 <sup>1/2"</sup> (590mm / 91mm / 520mm)
Cut-Out Dimensions (In / mm) (W / D)	22 <sup>1/16"</sup> / 19 <sup>5/16"</sup> (560mm / 490mm)

### WARRANTY

Parts & Labor	2 Years
---------------	---------

## Installation Details

### PRODUCT DIMENSIONS

In (W / H / D)	23 <sup>1/4"</sup> / 3 <sup>9/16"</sup> / 20 <sup>1/2"</sup>
mm (W / H / D)	590mm / 91mm / 520mm

### CUT-OUT DIMENSIONS

In (W / D)	22 <sup>1/16"</sup> / 19 <sup>5/16"</sup>
mm (W / D)	560mm / 490mm

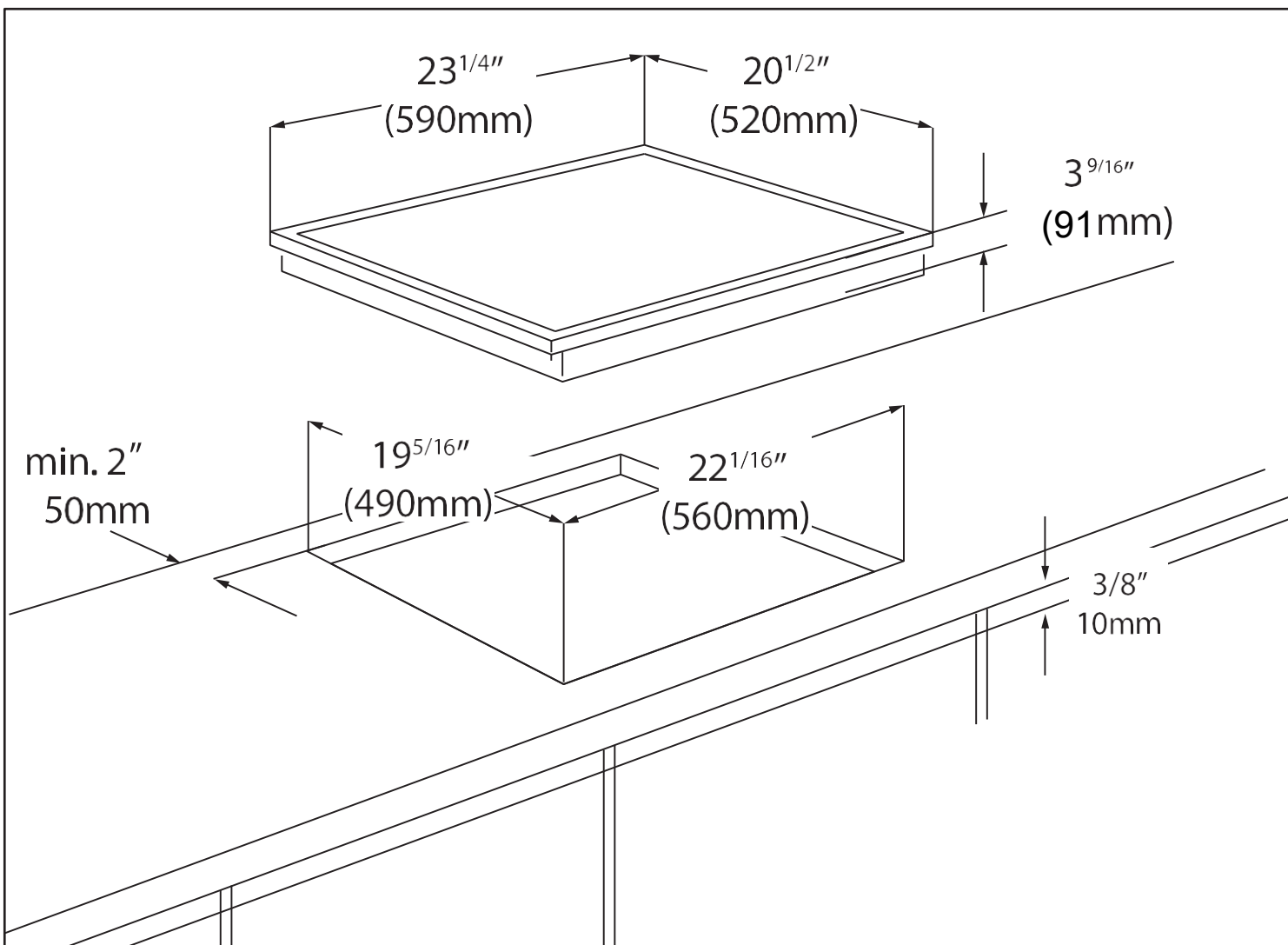

#### INSTALLING OVER BUILT-IN OVEN

- There must be a minimum of 20mm (13/16") of space left between the bottom of the cooktop and the oven to allow air to flow.
- There must be a minimum of 5mm (3/16") of space left between the counter top and the door panel of a built-in oven / drawer.
- If sufficient air flow is not provided, the life of the appliance will be shortened.

#### SIDE VIEW

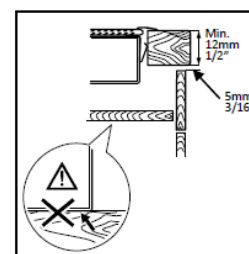

- Minimum distance from the cooktop cut-out to the wall: 2" (50mm).
- Minimum distance from the cooktop cut-out to the side wall: 1<sup>3/4"</sup> (44mm).
- Minimum distance from the cooktop surface to the range hood: 24" (610mm)

Other Product Downloads Available at [aeg-appliances.ca](http://aeg-appliances.ca)

# AEG

## WARRANTY INFORMATION

AEG Appliances are designed and manufactured to the highest standards. Each appliance is covered by a comprehensive 2-year parts and labour warranty. Refer to product warranty policy for complete terms and conditions.

## FOR PARTS & SERVICE

### Euro-Parts & Service

39822 Belgrave Road, Belgrave, ON. N0G 1E0 1 866 722 2262

[www.euro-parts.ca](http://www.euro-parts.ca) • [parts@euro-parts.ca](mailto:parts@euro-parts.ca) • [service@euro-parts.ca](mailto:service@euro-parts.ca)

AEG appliances are imported and distributed in North America by Euro-Line Appliances Inc. For more information, please visit one of our showrooms or [www.ela.ca](http://www.ela.ca)

### EURO-LINE APPLIANCES INC.

871 Cranberry Court  
Oakville, ON L6L 6J7  
Tell: 905.829.3980  
Toll-Free: 1-800.421.6332  
Email: [info@ela.ca](mailto:info@ela.ca)

### EURO-LINE APPLIANCES INC.

101-1014 Homer Street  
Vancouver, BC V6B 2W9  
604.235.3980  
1-855.352.9378  
[infowest@ela.ca](mailto:infowest@ela.ca)