

ARBM150SE2
**15 CU. FT.
BOTTOM MOUNT
REFRIGERATOR**

AVIVA



CONTROLS AND FUNCTIONS

Configuration	Single door
Freezer Type	Freezer Door
Temperature Management Control	Electronic soft touch control
Door swing	Reversible
Interior Lighting	LED lights
Refrigerator storage	1 large crisper, 3 large door bins + 2 adjustables door bins
Shelves	3 glass height-adjustable
Freezer storage	2 large drawers + 1 ice tray and ice bin

SPECIFICATIONS AND DIMENSIONS

Dimensions	27 5/8" (W) x 26 1/2" (D) x 67 3/4" (H)
Total Capacity	14.8 cu. ft. (Fridge 10.6. + Freezer 4.2)
Door Design	Slightly Curved
Handle Type	Recessed handle
Counter-Depth	Yes
Cabinet color	Grey
Finish Color	Stainless steel
Gas type	R600A
Energy Consumption	ENERGY STAR
Electrical requirements	120V / 60Hz / 15A
Warranty	2-years labor and replacement parts. Additional 3-years warranty, for a total of 5-years on the sealed system components only
UPC Code	628173080065

ARBM150SE2
15 CU. FT.
BOTTOM MOUNT
REFRIGERATOR

AVIVA

DIMENSIONS

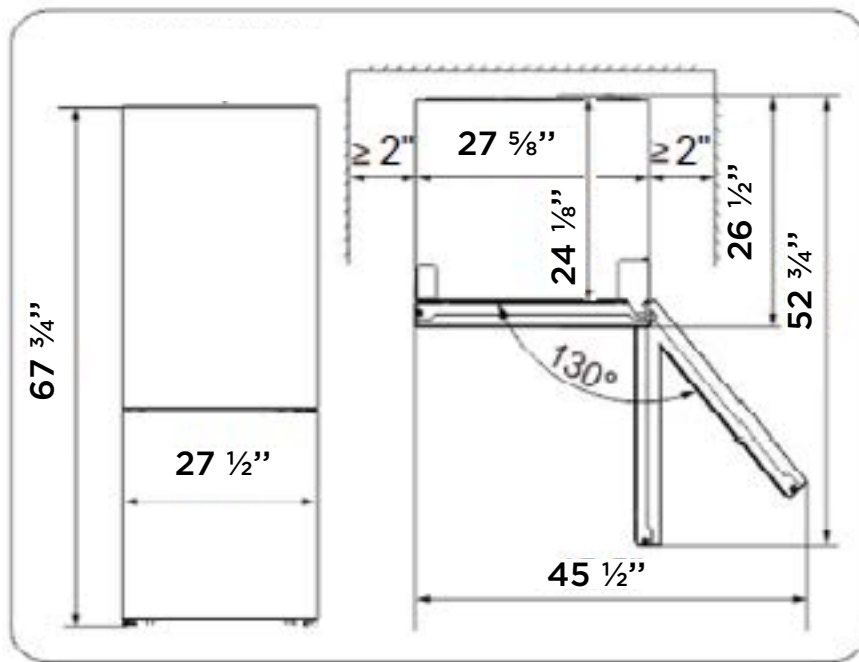

	Unit dimension	Box dimension
Width (In.)	27 5/8"	29 1/2"
Depth (in.) cabinet	26 1/2"	29"
Height (in.)	67 3/4"	72"
Weight NET/GROSS	Net: 70 kg/154 lbs	Gross: 77.56 kg/ 171 lbs
Width (without door)	25 1/2"	
Depth including door open to 90 degree	52 3/4"	
Width including door opened to 130 degree	45 1/2"	